

# TECHNICAL DATASHEET



RAK17061-09

chrome

Reference: RAK17061-09

Product: PEARL single lever high-raised XL basin mixer

## Product Description:

single lever XL basin mixer DN 15 with raised base  
single hole mounted  
solid lever  
ceramic cartridge with hot water safety device  
PCA aerator M24 x 1  
flow rate 3.8 ltr/min#  
flexible high pressure supply tubes 1/2 inch  
rapid installation set  
in accordance to EN 817  
Pressure Compensating Aerator 3.8 ltr/min (1 gpm)#

## Advertisement:

- \* KLUDI RAK LLC item no. RAK17061-09 PEARL single lever XL basin mixer with raised base
- \* chrome plated brass, in accordance to EN 50930-6
- \* in accordance to EN 817
- \* ceramic cartridge K-35 with hot water safety device

single lever basin mixer, with raised base, manufacturer KLUDI RAK LLC, KLUDI RAK PEARL item no. RAK17061-09, type: single lever XL HR basin mixer, DN 15/PN 10, chrome plated brass, solid lever, chrome plated metal, ceramic cartridge K-35, with hot water safety device, PCA aerator M24 x 1, flow rate 3.8 ltr/min, flexible high pressure supply tubes 1/2 inch, with DVGW/KIWA/WRAS/CSTBAT approval, rapid installation set, dimensions: height 345 mm, nozzle height 275 mm, nozzle projection 125 mm, lever projection 90 mm

## Line Drawing:

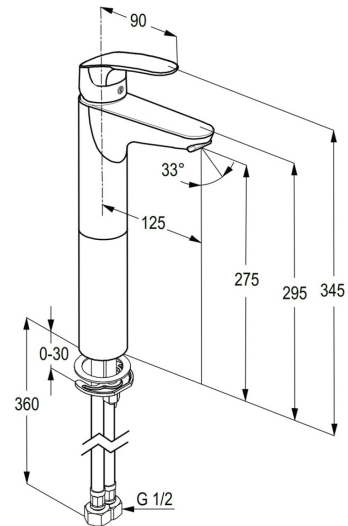

## Water Flow Rate#:

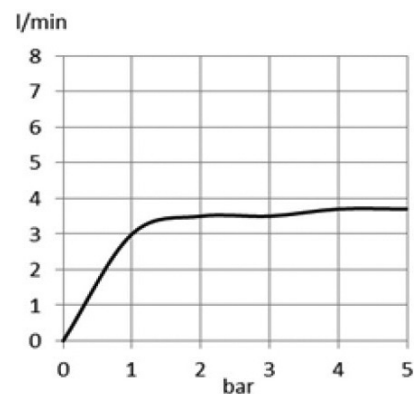

# variation: ± 15%



RAK17061-09 online

1/6/2021

**KLUDI**  
**RAK**  
"We Stand for Water Saving"