

# TECHNICAL DATASHEET

**Reference:** RAK16021-09\*

**Product:** SWING single lever high-raised basin mixer



\*RAK16021-09

Chrome Finish



\*RAK16021-09.GD1

Gold Color  
Glossy Finish



\*RAK16021-09.RG1

Rose Gold Color  
Glossy Finish



\*RAK16021-09.BK1

Black Color  
Glossy Finish

## Product Description:

single lever basin mixer high DN 15  
single hole mounted  
solid lever  
with raised base for use with counter-top basin  
ceramic cartridge with hot water safety device  
PCA aerator M24 x 1  
flow level 3.8 ltr/min (1 gpm)#  
flexible high pressure supply tubes 1/2 inch  
rapid installation set  
in accordance to EN 817  
Pressure Compensating Aerator 3.78 ltr/min (1 gpm)#

## Advertisement:

- \* KLUDI RAK LLC item no. RAK16021-09 SWING single lever basin mixer with raised base for use with counter top-basin
- \* Chrome plated/PVD Gold/PVD Rose Gold/PVD Black brass, in accordance to EN 50930-6
- \* in accordance to EN 817
- \* ceramic cartridge K-35 with hot water safety device

single lever basin mixer high, manufacturer KLUDI RAK LLC, KLUDI RAK SWING item no. RAK16021-09, type: single lever basin mixer high, DN 15/PN 10, Chrome plated/PVD Gold/PVD Rose Gold/PVD Black metal, ceramic cartridge K-35, with hot water safety device, aerator M24 x 1, flow level 3.78 ltr/min, flexible high pressure supply tubes 1/2 inch, with DVGW/KIWA/WRAS/CSTBAT approval, rapid installation set, dimensions: height 290 mm, nozzle height 265 mm, nozzle projection 119 mm, lever projection 88 mm

## Line Drawing:

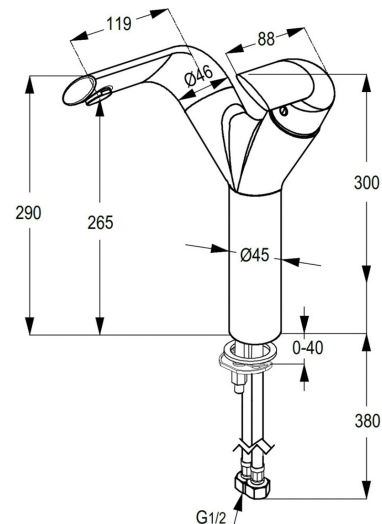

## Water Flow Rate#:

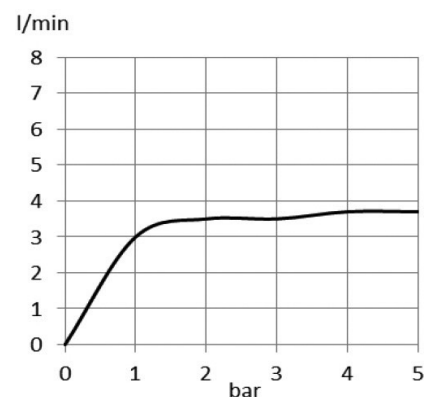

# variation: ± 15%



RAK16021-09 online

1/6/2021

**KLUDI**  
**RAK**

"We Stand for Water Saving"