

REFERENCE

REF: 40484640

EAN: 8421152145715

FEATURES

Island hood
 EcoPower motor
 Energy Efficiency class: A
 Electronic panel
 White display
 Operating pilot light
 3 speeds + 1 intensive
 Exhaust capacities:
 Free Outlet, m³/h: 920
 Qboost, m³/h: 796
 Max., m³/h: 605
 Min., m³/h: 311
 Noise (LwA) Boost Speed, dB: 71
 Noise (LwA) Max Speed, dB: 66
 Noise (LwA) Min Speed, dB: 52
 4 LED lamps
 4/3 stainless steel-aluminium filters
 Reinforced Black Glass
 Easy to clean inside panel
 Stop delay timer
 Filter saturation indicator

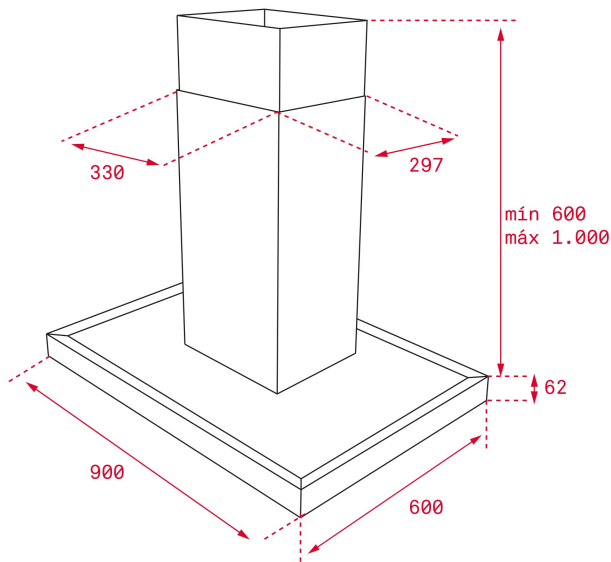

LED

Stop Delay
Timer

DIMENSIONS

Product height (mm): 817 / 1117 + 62**Product width (mm):** 900**Product depth (mm):** 600**Product length (mm):****Net weight (Kg):** 36,01

TECH SPECS

Energy Efficiency Class: A
 Noise (LwA) Min Speed (dB): 52
 Noise (LwA) Max Speed (dB): 66
 Noise (LwA) Boost Speed (dB): 71
 Ø Outlet (mm): 150

COLOURS



40484640

Stainless Steel