

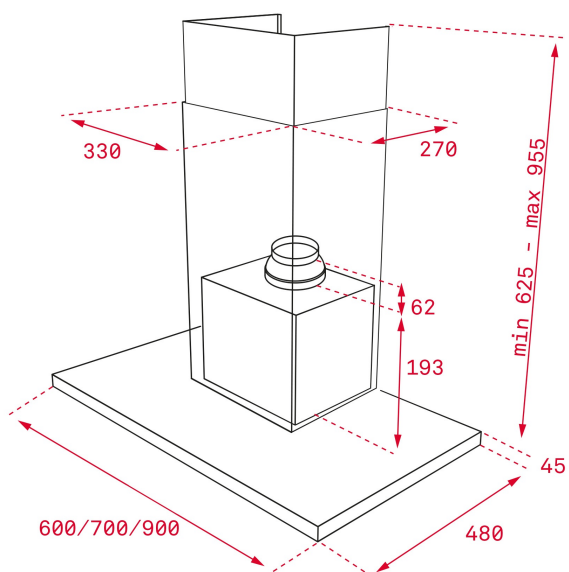

LED

Stop Delay
Timer

REFERENCE

REF: 40484202

EAN: 8421152157350

FEATURES

EcoPower motor
 Energy Efficiency class: A
 Electronic control
 Digital display
 3 speeds + 1 intensive
 Stop delay timer
 Noise(*): min. 54 dBA - máx. 68 dBA
 LED Light Bar
 2 Stainless steel filters
 Stop delay timer
 Filter saturation indicator

DIMENSIONS

Product height (mm): 670-1000

Product width (mm): 900

Product depth (mm): 480

Product length (mm):

Net weight (Kg): 15,33

TECH SPECS

Energy Efficiency Class: A
 Noise (LwA) Min Speed (dB): 54
 Noise (LwA) Max Speed (dB): 67,8
 Noise (LwA) Boost Speed (dB): 72
 Ø Outlet (mm): 150

COLOURS



40484202

Stainless Steel