

Ventilating Fan Specifications

Model 30KQT

		110V		120V		127V		220V		230V		240V
		50Hz	60Hz	50Hz	60Hz	50Hz	60Hz	50Hz	60Hz	50Hz	60Hz	50Hz
Air Volume	CMH \pm 10%	1,180	1,260	1,300	1,320	1,330	1,440	1,220	1,270	1,230	1,320	1,260
Power Consumption	W \pm 15%	40	48	45	55	49	60	42	51	44	54	47
Current	A \pm 15%	0.37	0.44	0.38	0.46	0.39	0.47	0.19	0.24	0.19	0.24	0.20
Speed	R/M \pm 10%	1,160	1,190	1,210	1,310	1,240	1,350	1,190	1,260	1,210	1,300	1,240
Noise	dB	46.5	46.5	48	49	48.5	50.5	45.5	46.5	46	47.5	46.5

at 0mmAq. Static pressure.

- | | |
|--------------------------------|--|
| 1. Power Rating ----- | 1 Pasa AC 110-127V 50/60Hz
1 Pasa AC 220-240V 50Hz. AC 220V-230V 60Hz |
| 2. Motor Type ----- | Capacitor start and run induction motor.Class E.4 Poles |
| 3. Blade Type ----- | Propeller fan |
| 4. Ambient temperature ----- | - 10 to 50 deg.C |
| 5. Insulation Resistance ----- | More than 1 meg ohm |
| 6. Electric Strength ----- | AC 1500V 1 minute |
| 7. Weight ----- | 4.9 Kg |
| 8. Color ----- | White |

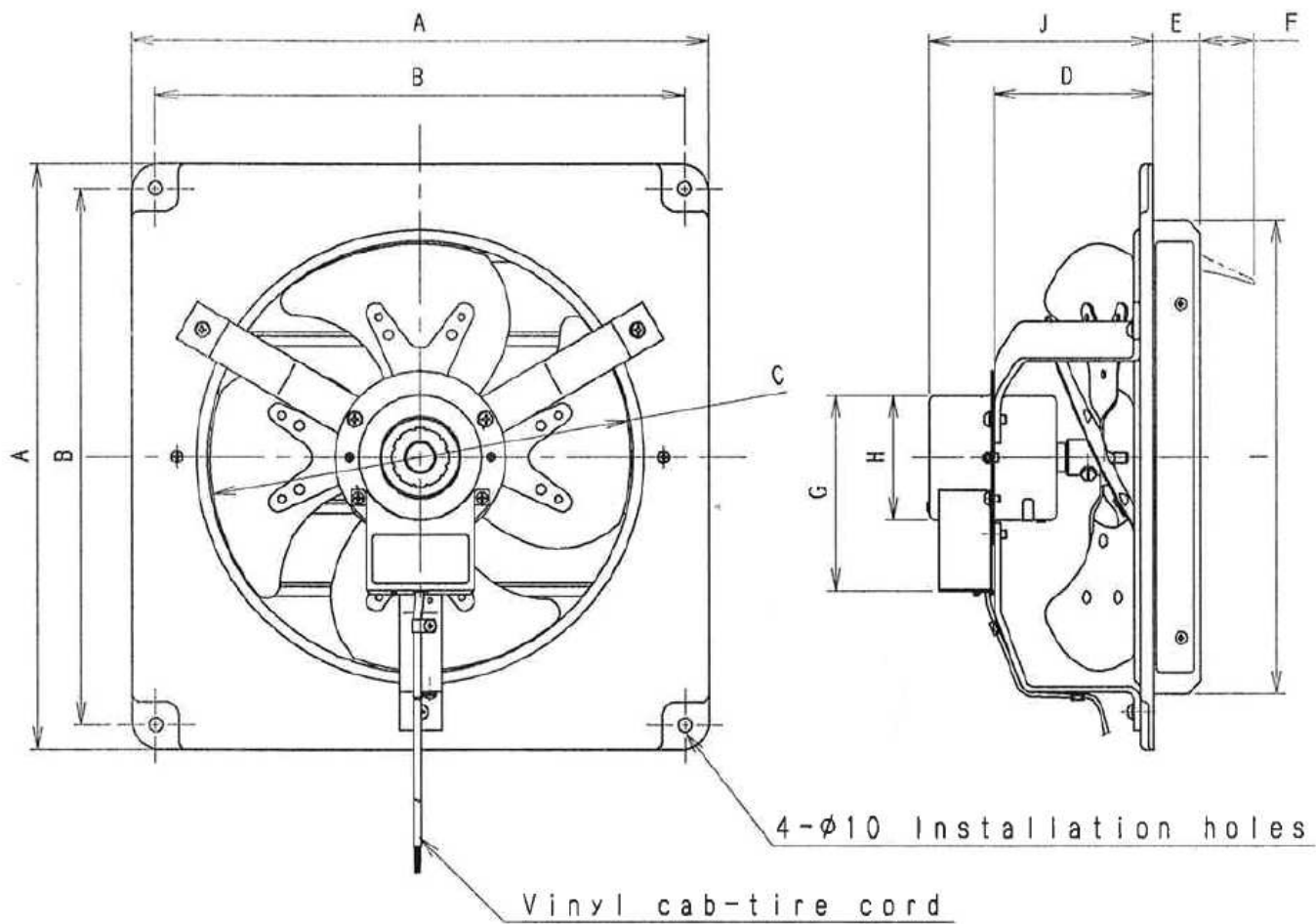

Dimensions :mm

Model : 30KQT

A	B	C	D	E	F	G	H	I	J
420	385	307 dia.	116	34	40	141	90 dia.	340 sq.	164

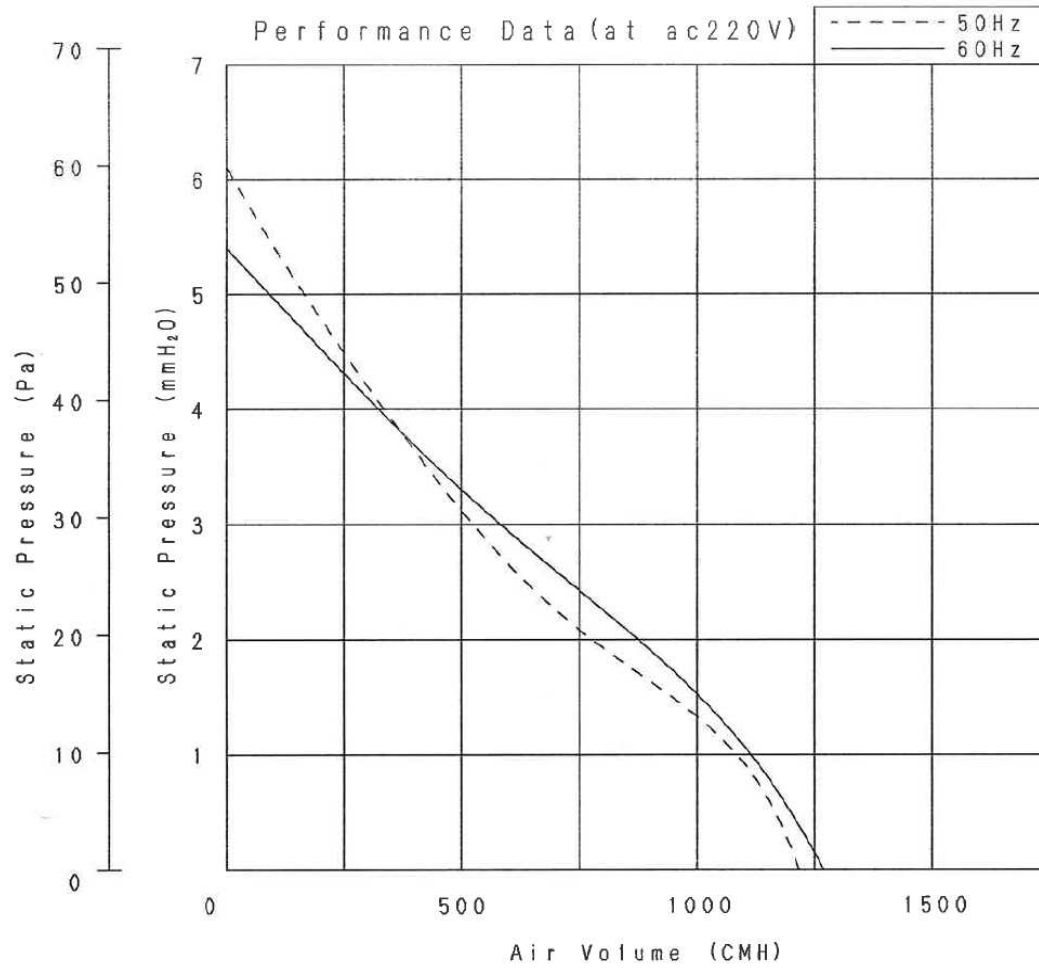

Model : 30KQT